

* incl. 20 [-5; +30] mm pull out

3D model is available on request or www.hyva.com

| Specifications | | Max. pump flow | | Tipping time | |
|---|---------|-------------------------------------|-----------|-------------------------------------|--------|
| Max. working pressure | 250 bar | With KO ¹ | 190 L/min | With KO ¹ | 31 sec |
| Weight | 338 kg | Without KO ¹ | 137 L/min | Without KO ¹ | 43 sec |
| Working volume | 98 L | With KO ¹ below -20°C | 133 L/min | With KO ¹ below -20°C | 44 sec |
| Total volume | 106 L | Without KO ¹ below -20°C | 96 L/min | Without KO ¹ below -20°C | 61 sec |
| Max. cyl. load (start tipping) | 245 kN | | | Allowable lowering time | 31 sec |
| Max. cyl. load (end of stroke) ² | 121 kN | | | | |
| Max. cyl. load (end of stroke) ³ | 141 kN | | | | |

Technical notes

- This cylinder is a lifting device only.
- It should not be used as a structural member and should not be subjected to side loads.
- Tipping valve must have a pressure relief at the cylinder port set not higher than max. working pressure.
- Verify max. cyl. load.
- Working temperature range is between -40°C and +80°C.
- Max. duration of extension is 0.5 hours (excluded hard chromed stages).
- Cylinder is painted black (RAL9005) with a min. thickness conforming to the 480 hours neutral salt spray test as per ISO 9227.
- ¹ Hyva knock-off.
- ² Unsubstantial unloading (sticky load).
- ³ Substantial unloading.

Related documentation

- Bracket options: 015BRA10 & 015BRA12
- Mounting instructions: CYL-0030
- Oil specifications: OIL-0011
- Spec sheet explanation: CYL-0041

Configuration

| Extension | 1 | 2 | 3 | 4 | 5 | 6 | 7 | Total |
|-------------------------|------|------|------|------|------|---|---|-------|
| Effective diameter [mm] | 169 | 149 | 129 | 110 | 91 | | | |
| Stroke* [mm] | 1410 | 1430 | 1430 | 1430 | 1430 | | | 7130 |

Tipping weight

For detailed tipping calculations please refer to: <https://tipper.hyva.com>

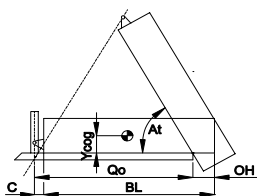

- BL body length
 - OH rear overhang
 - Ycog vert. pos. centre of gravity
 - Qo pivot length
 - C bracket length
 - At tipping angle
- $stroke \times 60 / Qo$

| BL [mm] | 9500 | 800 | 9150 | 800 | 8800 | 800 | 800 | 800 |
|-----------|------|-----|------|-----|------|-----|-----|-----|
| OH [mm] | 500 | 800 | 500 | 800 | 500 | 800 | 500 | 800 |
| At [°] | 44 | 46 | 47 | 46 | 48 | 49 | 48 | 52 |
| Ycog [mm] | 600 | 47 | 50 | 45 | 48 | 52 | 47 | 54 |
| | 44 | 47 | 50 | 45 | 48 | 52 | 47 | 54 |
| | 49 | 53 | 54 | 51 | | | | |

Tipping weight [ton] at maximum pressure of 250 bar for a vertically mounted cylinder and C is 229 mm

| Pos. | Part no. | Description | Qty. |
|------|-----------|-------------------------------|------|
| C01 | 71839040 | DUST COVER FC LOW 15-244 | 1 |
| C02 | 71706635 | COVER 242-1445 PIN60 A340 FIX | 1 |
| C03 | 01702956K | WASHER M48 DIN 125B ZP | 1 |
| C04 | 01702907K | TOPNUT NYLOC M48x3 DIN 985 ZP | 1 |
| P01 | 74462651 | PISTON FL3 S 091-1645-HC | 1 |
| P02 | 71853091K | SLIDER FL 091 (2 X 1/2) A22 | 1 |
| P03 | 71851091K | OUTER STOPRING FL 091 A22 | 1 |
| P04 | 71822091 | BOTTOM PLATE PISTON FL 091 | 1 |
| P05 | 01745012K | CIRCLIP 82 DIN 472 (87.5x2.5) | 1 |
| P06 | 71870215K | O-RING PISTON BOTTOM 091 | 1 |
| P07 | 71848200 | PISTON HEAD FL 091 MK2 | 1 |
| P08 | 01226430K | O-RING 72.62 X 3.53 MM | 1 |

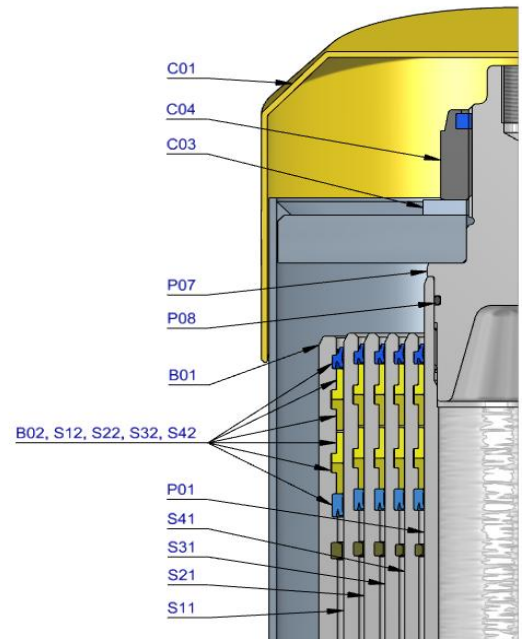

| | | | |
|-----|-----------|-----------------------------|---|
| S41 | 74603650 | STAGE FL2 110-1640 | 1 |
| S42 | 71802110K | PACKSET FL 110 | 1 |
| S43 | 71853110K | SLIDER FL 110 (2 X 1/2) A22 | 1 |
| S44 | 71851110K | OUTER STOPRING FL 110 A22 | 1 |
| S45 | 71852110K | LIFTRING FL 110 A22 | 1 |

| | | | |
|-----|-----------|-----------------------------|---|
| S31 | 74604650 | STAGE FL2 129-1640 | 1 |
| S32 | 71802129K | PACKSET FL 129/HP 129 | 1 |
| S33 | 71853129K | SLIDER FL 129 (2 X 1/2) A22 | 1 |
| S34 | 71851129K | OUTER STOPRING FL 129 A22 | 1 |
| S35 | 71852129K | LIFTRING FL 129 A22 | 1 |

| | | | |
|-----|-----------|---------------------------|---|
| S21 | 74605650 | STAGE FL2 149-1640 | 1 |
| S22 | 71802149K | PACKSET FL 149/HP 150 | 1 |
| S23 | 71807151K | SLIDER FL 149 A35 | 1 |
| S24 | 71851149K | OUTER STOPRING FL 149 A22 | 1 |
| S25 | 71852149K | LIFTRING FL 149 A22 | 1 |

| | | | |
|-----|-----------|---------------------------|---|
| S11 | 74606650 | STAGE FL2 169-1640 | 1 |
| S12 | 71802169K | PACKSET FL 169 | 1 |
| S13 | 71807171K | SLIDER FL 169 A35 | 1 |
| S14 | 71851169K | OUTER STOPRING FL 169 A22 | 1 |
| S15 | 71813169K | LIFTRING FL 169x5 | 1 |

| | | | |
|-----|---------------|------------------------------------|---|
| B01 | 74507650R1345 | BASE FL2 191-1683-4/4BSAE-190-C242 | 1 |
| B02 | 71802191K | PACKSET FL 191 | 1 |
| B03 | 71825430 | BOTTOM PLATE FL2 191 | 1 |
| B04 | 71870040K | SEAL BOTTOM PLATE FL 191 | 1 |
| B05 | 71820195 | LOCKING PLATE FL2 191 | 3 |
| B06 | 01732055K | BOLT HEX M8X20X1.25 SET 6 PCS | 1 |
| B07 | 01732559K | WASHER SPRING M8 SET 6 PCS | 1 |

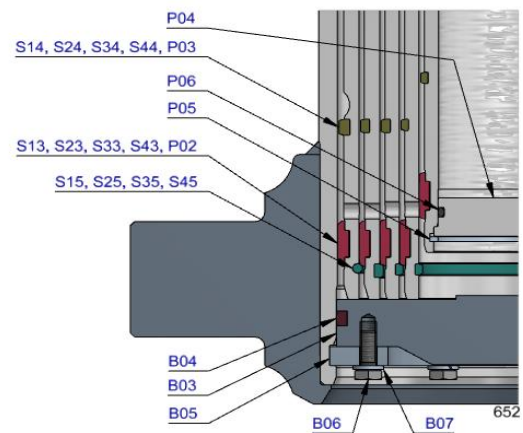
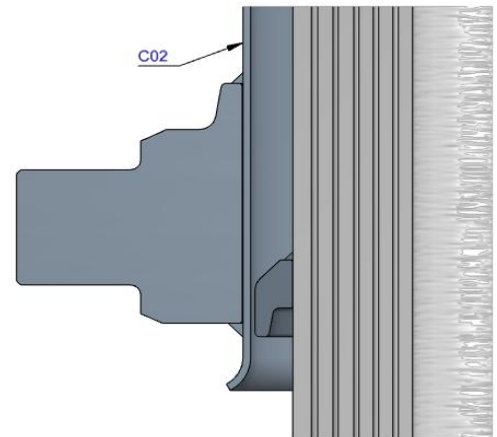

Seal kit complete

| | |
|-----------|--|
| 71908650K | Consists of all packsets with packset grease and O-rings |
|-----------|--|

Notes

The inner stopring and piston bottom are pre-mounted on spare bases, stage and pistons. Therefore, when ordering new tubes, it is not required to order these parts separately.

For repair instructions see: CYL-0040. Serial no. is located on type plate and near type plate support.